

## SKYSOL 2 MANUAL - Installation Instructions

### Unpacking and Initial Installation

Check blind is the correct one for the window by measuring the width/drop dimensions – see label on plastic sleeve – as shaped handed pairs can look similar.

Take off elastic bands and ensure the cords and wires are free from obstruction. Allow blind to open by holding the head rail and letting the moving rail and/or bottom rail drop.

Offer blind up to window to determine the positions for the mounting brackets. The recommended locations for the fixing brackets are indicated on the back of the head rail (and the inside of the bottom rail on 3 bar blinds) by a round black sticker. Make sure that there is enough room behind the brackets to be able to access the release clip.

### Head rail Brackets

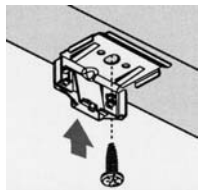

Top Fix Mounting

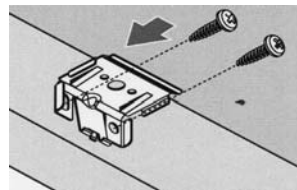

Face Fix Mounting

### 2 Bar Bottom Fixing Blocks

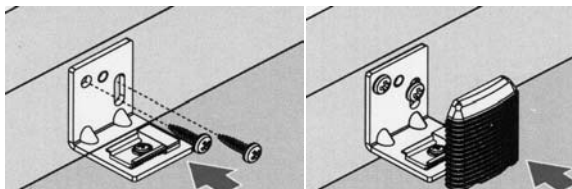

Face Fix Mounting

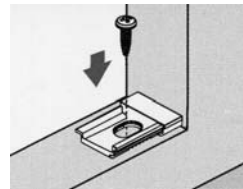

Top Fix Mounting

### 3 Bar Bottom rail Brackets

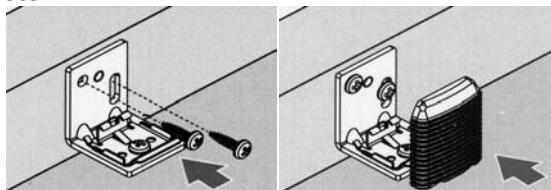

Face Fix Mounting

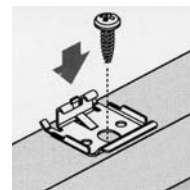

Top Fix Mounting

For a 2 bar blind the cords/guide wires need to run in a straight line centrally through the holes in the fabric. The vast majority of blinds require the cords/guide wires to be mounted perpendicular to the head rail. Make sure you position the fixing blocks correctly. Once all brackets are in place clip the head rail into its brackets.

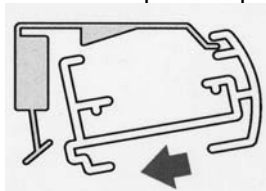

Head rail - Clipping into Position A

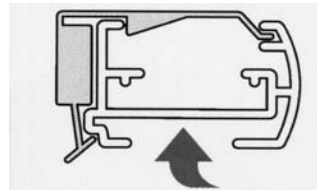

Head rail - Clipping into Position B

Then clip the bottom rail or bottom fixing blocks in place, make sure that the head rail and bottom rail or fixing blocks are aligned.

### 2 Bar Bottom Fixing Blocks

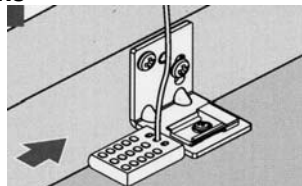

Clipping into Position Face Fix

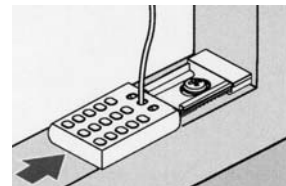

Clipping into Position Top Fix

### 3 Bar Bottom rail

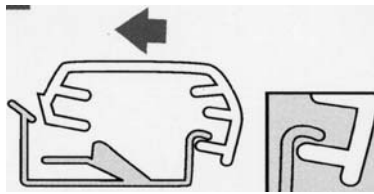

Clipping into Position A

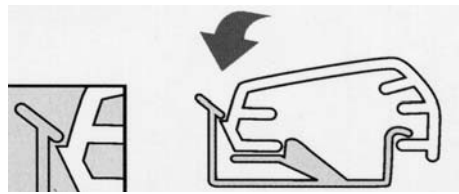

Clipping into Position B

Check the spring tension of the cords by running the blind up and down. The higher the spring tension the more friction created and the firmer the moving rail. Too loose and the moving rail will fall under its own weight, too tight and it will not move.

### Adjusting the Blind Tension

If you need to adjust the tension you will need to adjust both the cords and the guide wires.

To alter the cord tension first unclip the head rail.

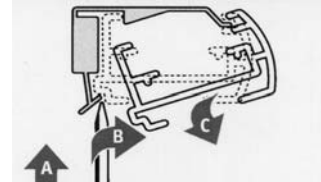

Head rail - Removal

Remove one endcap from the head rail and slide out the plastic capping to reveal the springs. It is advisable to mark the cord at the knot to show where the original setting was in relation to the spring. Undo the knot and to increase tension pull the mark closer to the spring, to decrease tension allow the mark to move away from the spring. Once re-tensioning has been completed ensure the knots cannot slip.

Check the tension of the blind once more by offering up the head rail to its brackets and re-checking the tension, if necessary repeat the above process.

To alter the guide wire tension on a 2 bar blind, remove one endcap from the head rail and slide out the capping strip. Identify the spring(s) requiring retensioning. Loosen the 2mm grub screw in the barrel clamp next to the spring and pull the loose end of the guide wire to increase the tension, while under load tighten the grub screw. Now offer the blind to its head rail clips, if necessary repeat the above process. Replace capping and endcap once the correct tension has been set.

To alter the guide wire tension on a 3 bar blind use the quick tension system on the bottom rail. Do this with the red handle provided in the spares kit. The red handle is placed over the bottom rail, clipping onto the quick tension unit, slide this handle to increase/decrease tension on the guide wire. Where possible leave this action until the blind is in its fixing clips so that you may put tension onto the guide wires without making it difficult to mount. The guide wires are to be as tight as possible to stop any unwanted movement in the blind.

Trim over-length guide wire ends (around 75mm [3"] to allow for further re-tensioning if needed) and tuck tails into the head rail. Excess cord/guide wire at fixing blocks can now be trimmed.

Before clipping the blind in place replace the plastic capping and endcap that was removed to perform the adjustments.

Finally align the head rail with its opposite fixings and clip into position, if the fabric appears to be pinching at one side and fanning at the other you may need to unclip and re-align the head rail or bottom rail/fixing blocks and then re-check the guide wire tension. If at this stage the guide wire tension is inadequate then unclip the head rail (if necessary) and repeat the above



Bottom rail - Removal

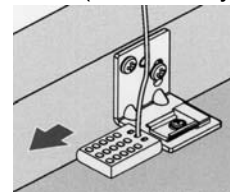

Fixing Block - Removal

### General Points

Shaped Blinds – Ensure that there is sufficient space between the edges of the blind and the recess, so that the fabric does not foul on the recess at any time.

Any puckering of the blind means the blind has not been set up as per the original dimensions given – check the head rail is in the correct alignment in relation to the bottom rail/fixing blocks. Alternatively the initial measurements were incorrect.

Ensure the fabric is kept clean at all times and take care not to crush the pleats

### Manual, 2 Bar, Face Fix Top Stack

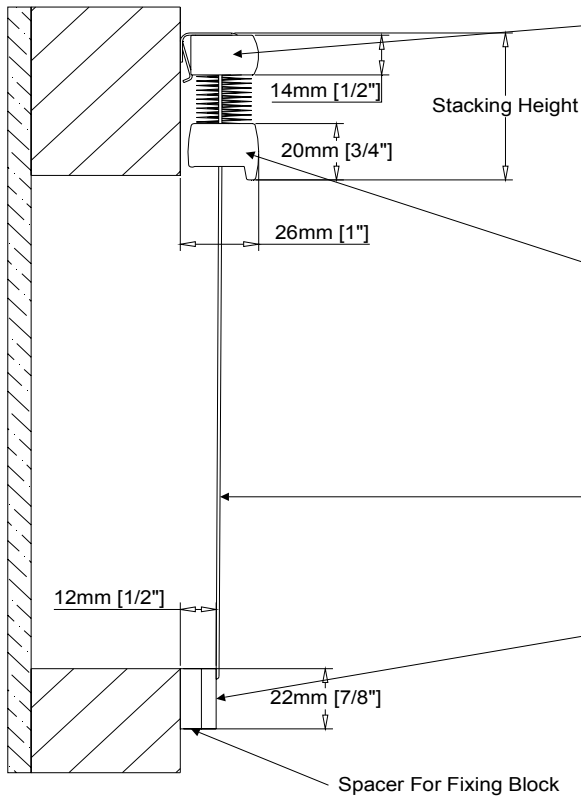

### Manual, 2 Bar, Top Fix Top Stack

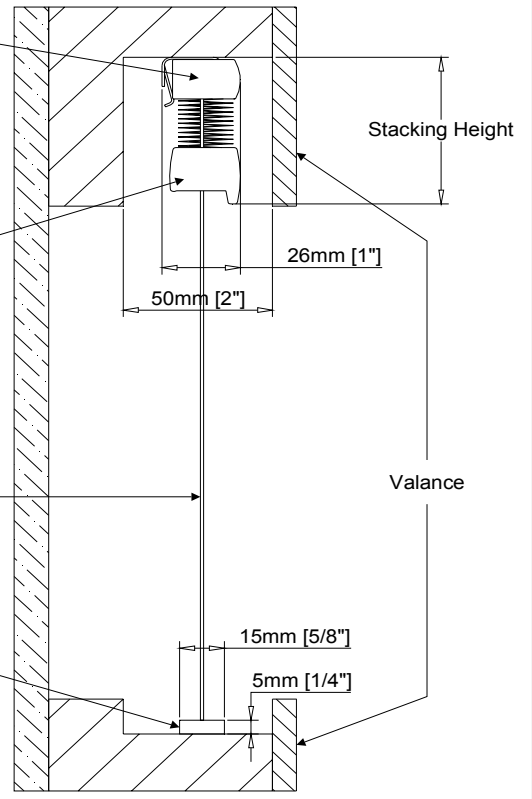

### Manual, 3 Bar, Face Fix Top Stack

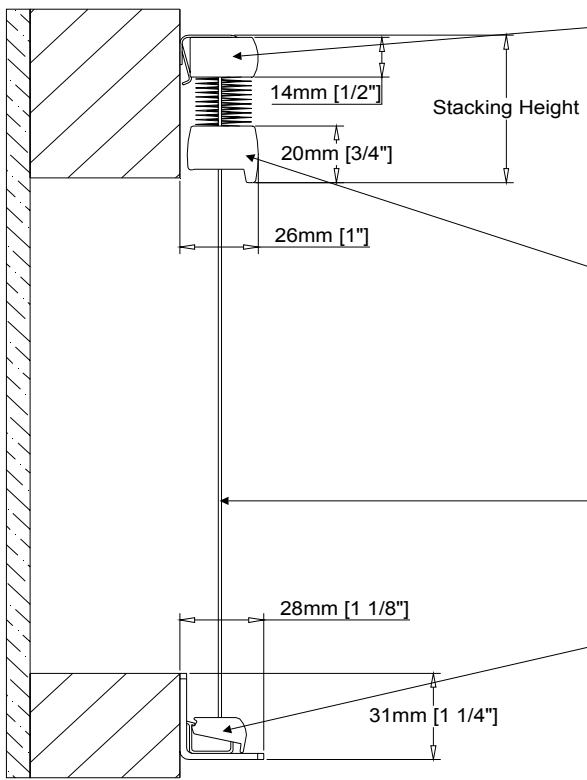

### Manual, 3 Bar, Top Fix Top Stack

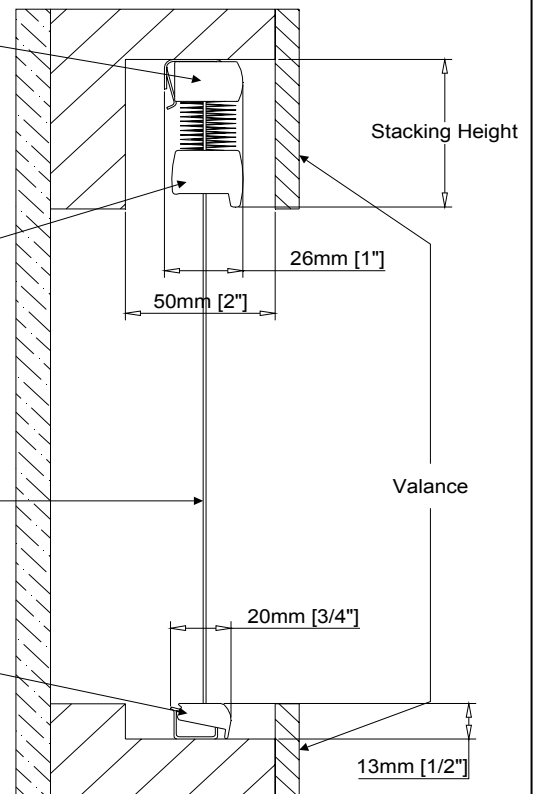

### Manual, 2 Bar, Face Fix Bottom Stack

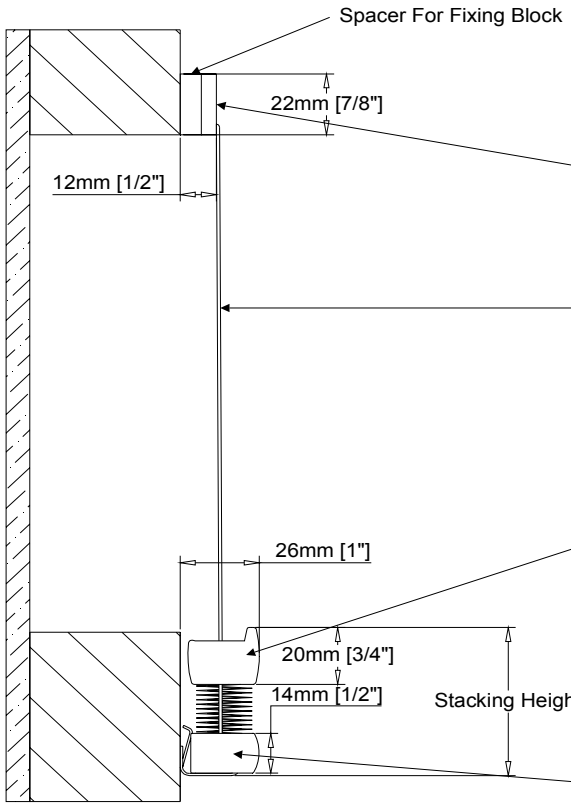

### Manual, 2 Bar, Top Fix Bottom Stack

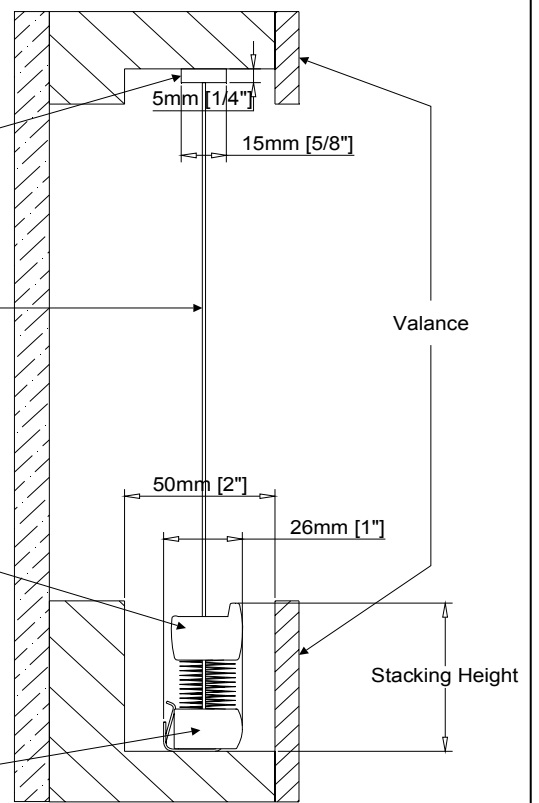

### Manual, 3 Bar, Face Fix Bottom Stack

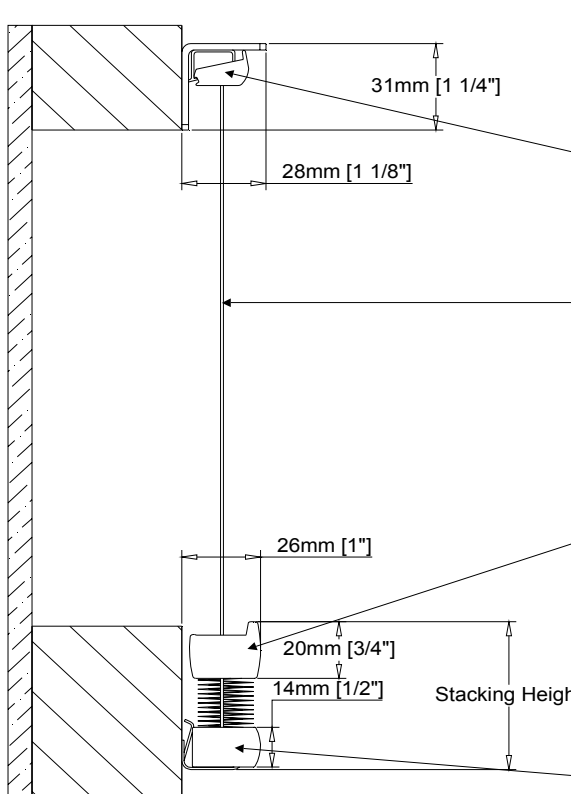

### Manual, 3 Bar, Top Fix Bottom Stack

