

Minimum radius = 75mm

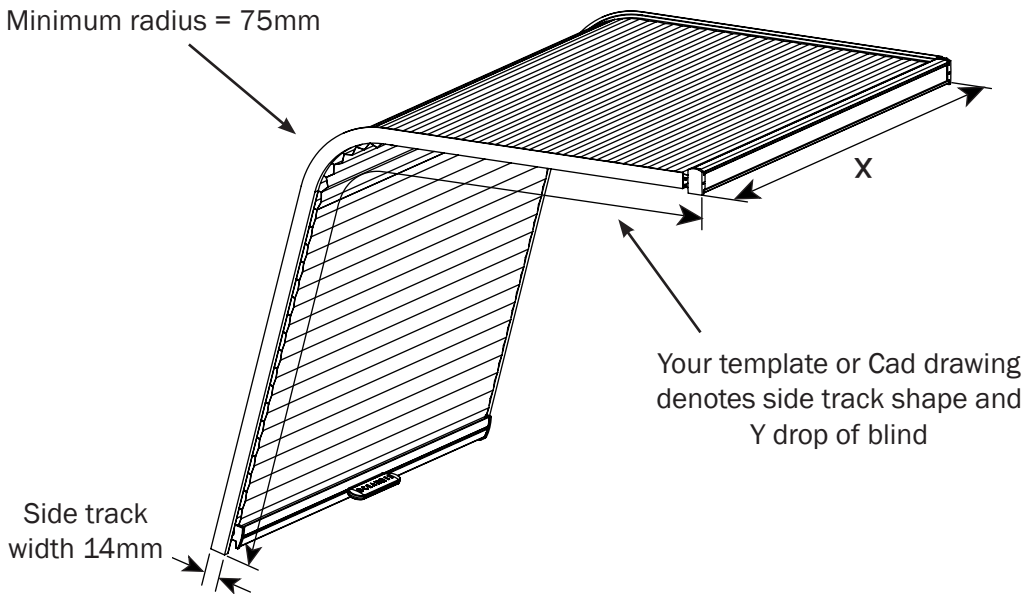

Recommended minimum  
recess depth  
manual = 50mm  
powered = 75mm

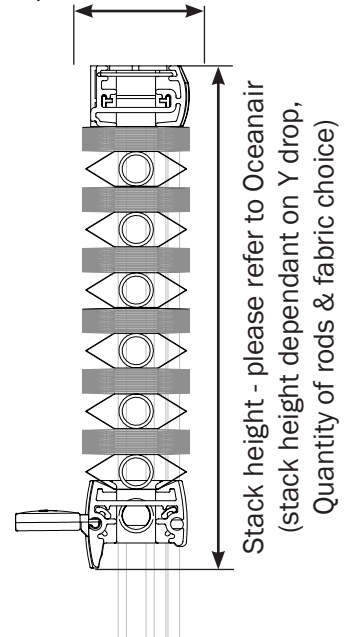

**Design / Technical Points**

- Manual companionway blind designed specifically for curved installations.
- Maximum recommended blind size 1200mm (47¼") wide by 2000mm (73¾") drop. Outside these sizes, please contact Oceanair.
- Fabric is 25mm Duette® cellular polyester available in variety of colours, opaque and blackout.
- Aluminium cross bar and headrail are available in white, beige, graphite or custom colour finish.
- Aluminium side tracks are available in white, beige, aluminium or custom colour finish.
- Aluminium Internal rods with gliders for stability and durability.
- Fast and simple to fit using Oceanair's proven spring clip system, fixing bracket with headrail depth - manual 26mm / powered 33mm.
- Concealed cord tension system.
- Top and bottom must be parallel, as must the sides (Up to 10mm tolerance for variable hatch widths).
- Top and bottom stacking options.
- Top or face mount.
- Powered option also available – please contact Oceanair.

**How to order**

- Complete the STS custom order form (document No. OAT00130)
- Templates/CAD drawings will be needed for curved track profile.

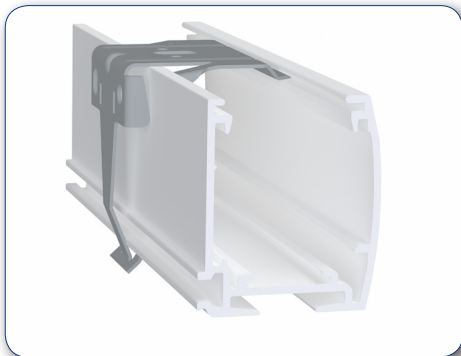

Headrail for powered blind operation

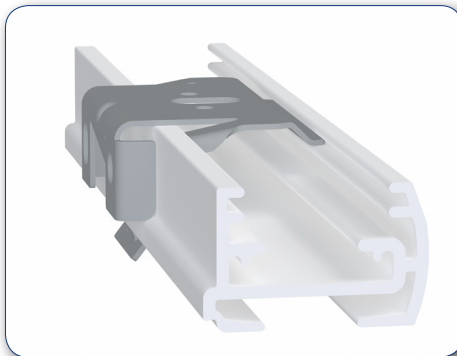

Headrail for manual blind operation

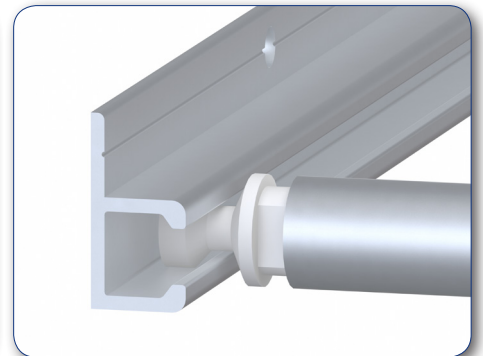

Side track, glider & internal rod detail