

CUSTOM ORDER FORM

Recessed SKYscreen (Mk 5)

flyscreen and blackout blind made by **OCEANair**

Customer:	Is this an Order or Quote? Please tick	Date:
Customer ref:	Order <input type="checkbox"/> Order No <input type="checkbox"/> Quote <input type="checkbox"/>	Tel/Fax

Please note that despatch of custom units will be confirmed on receipt of order

Item	Internal ¹		OR Overall ⁴		Qty	Frame colour	Radius ⁵	Special Requirements
	Width (X) ²	Drop (Y) ³	Width (A)	Drop (B)				
1						<input type="checkbox"/> Beige <input type="checkbox"/> White	<input type="checkbox"/> R30 <input type="checkbox"/> R50 <input type="checkbox"/> R42	
2						<input type="checkbox"/> Beige <input type="checkbox"/> White	<input type="checkbox"/> R30 <input type="checkbox"/> R50 <input type="checkbox"/> R42	
3						<input type="checkbox"/> Beige <input type="checkbox"/> White	<input type="checkbox"/> R30 <input type="checkbox"/> R50 <input type="checkbox"/> R42	
4						<input type="checkbox"/> Beige <input type="checkbox"/> White	<input type="checkbox"/> R30 <input type="checkbox"/> R50 <input type="checkbox"/> R42	

Complete either internal OR external measurement, whichever is the more critical

- ¹ X and Y dimension are taken from the centre of the seal
- ² X Max width 1100 mm (43¹/₄"), Min width 200mm (7⁷/₈") defined as roller side
- ³ Y Max drop 900 mm (35³/₈") for full blind and flyscreen or Max 1000 mm (39³/₈") for half blind or flyscreen where the blinds meet in the middle
- ⁴ Recess size = A less 24mm (1") by B less 24mm (1")
- ⁵ Radius: The standard corner radii cover between R30 28mm-39mm (1¹/₈" -1⁹/₁₆"), R42 42mm-48mm (1⁵/₈" -1⁷/₈"), R50 49mm-58mm (1¹⁵/₁₆" -1⁹/₃₂")

Notes: Blinds over 750mm wide have two handles
 For Mk V Recessed SKYscreen with liner, see separate Custom Order Form
 Dimensions converted to nearest 1/8" - if size critical order using metric measurements.

Carriage	
Sub Total	
VAT	
Total	
Job No.	
Despatch Date	

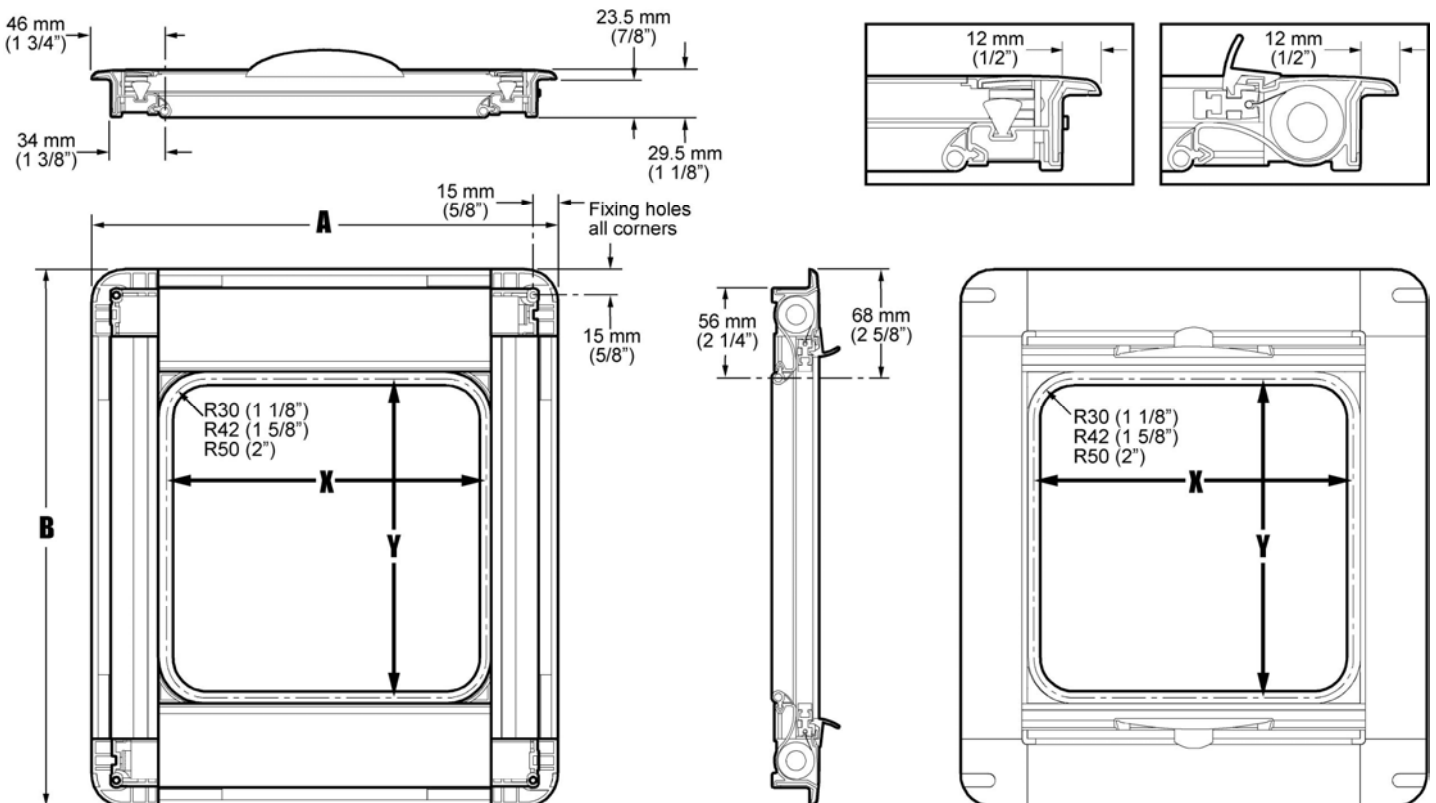

Oceanair Marine Limited Chichester PO20 0AY England

t: +44 (0)1243 606909 f: +44 (0)1243 608300 www.oceanair.co.uk e: TechSupport@oceanair.co.uk