

# VENT and LIGHT – Technical Sheet 39

## Dimensions

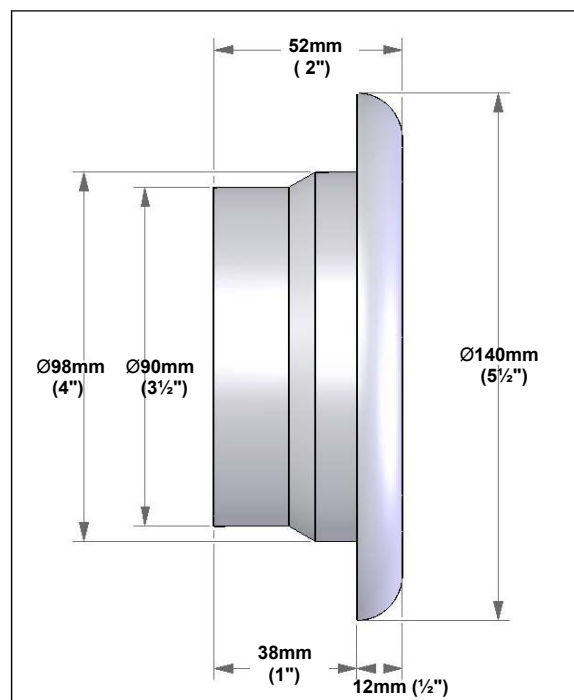
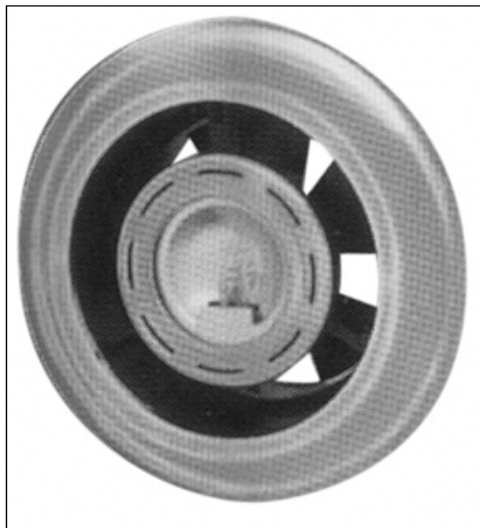

## Features

- A unique combination unit comprising exhaust fan and halogen light
- Low power consumption
- Ultra quiet operation
- Approximately 50,000 hours life span—i.e., 6 years continuous operation
- Light and Fan may be configured for separate or combined operation
- Easy to install
- Available in Gold, White or Chrome finish

## Install Design Points

- Ceiling or Bulkhead mount through 100mm (4") hole
- Compatible with standard hose and ducting fittings

## How to Order

- Contact Oceanair stating required voltage and trim colour

## Technical Specification

- 12 (Model BSL112) or 24 VDC (Model BSL124) units available
- Airflow 18 litres/second (38 cubic feet per minute) - without ducting
- Power consumption, fan only, 2.8 watts
- Max G4 lamp rating: 20 Watts
- Fan maximum noise level 43.0 dB(A)

Oceanair Marine Limited Chichester PO20 0AY England  
t: +44 (0)1243 606909 f: +44 (0)1243 608300 www.oceanair.co.uk e: TechSupport@oceanair.co.uk