

## General Arrangement Drawing

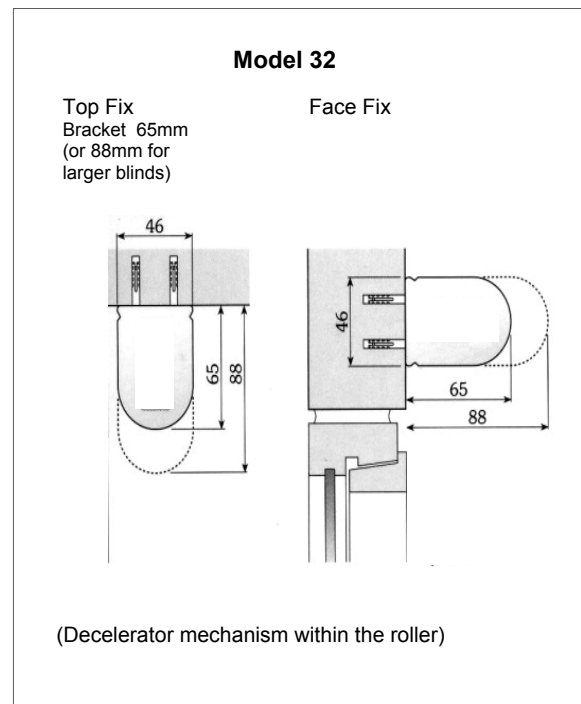
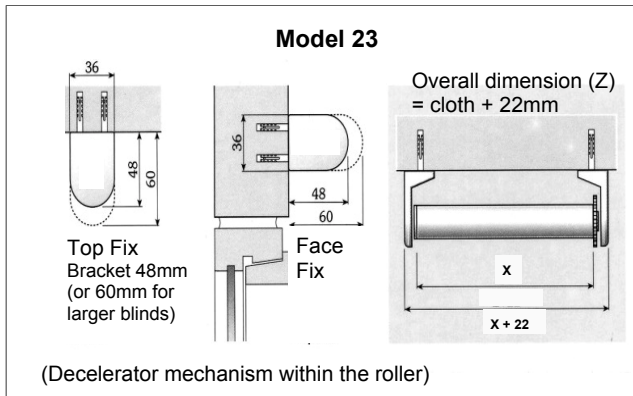

## Features

- Spring loaded blind with ratchet option
- Decelerator option returns cloth to roller in a smooth controlled fashion thus preventing any damage that could occur if the operator just let go.
- Different size components tailored to size of blind
- Adjustable tension

## Install Design Points

- Top or face fix options
- Easy roller release mechanism
- Guide wire systems available to keep the blind steady and allow for mounting at small angles off the vertical
- Available with white or beige crossbars
- Variety of hold-down options

## Custom

- Max recommended width (X) 3000 mm (118<sup>1</sup>/<sub>8</sub>" ) for Model 32, 1500 mm (59" ) for Model 23

## How to Order

- To order use our Custom Order Form

## Technical Specification

- Blind fabric – may be customer supplied or chosen from Oceanair range
- Model 23 – minimum width 575mm (22<sup>5</sup>/<sub>8</sub>" )
- Roller diameter for Model 23 is 23mm (7<sup>1</sup>/<sub>8</sub>" )
- Model 32 – minimum width 753mm (29<sup>5</sup>/<sub>8</sub>" ) - houses the decelerator mechanism in the brackets
- Roller diameter for Model 32 is 32mm (1<sup>1</sup>/<sub>4</sub>" ) or 36mm (1<sup>1</sup>/<sub>2</sub>" ) for larger blinds

**Oceanair Marine Limited** Chichester PO20 0AY England

t: +44 (0)1243 606909 f: +44 (0)1243 608300 www.oceanair.co.uk e: TechSupport@oceanair.co.uk